

The Tellun Corporation

TLN-867 Tuner & Headphone Monitor

User Guide, Rev. 1.0.2

Scott Juskiw
The Tellun Corporation
scott@tellun.com

TLN-867 User Guide
Revision 1.0.2
December 11, 2008

1. Introduction

The TLN-867 Tuner & Headphone Monitor combines an A440 reference tone generator, a headphone amplifier, and a beat frequency indicator all in a 1U module. The A440 generator is none other than David Brown's excellent DJB-A440 Reference Oscillator, a super stable digital A440 tone generator.

No matter how large your synthesizer is, you don't need more than one A440 tone generator module. A dedicated A440 module would only have a single output jack which, IMHO, is a waste of an entire 1U panel. If, like me, you have just the one head with two ears on it (a mono head), then a headphone monitor is another useful module that you only need one of. Combining the two together makes even more sense should you want to tune your oscillators without sending the A440 tone to your output amp for everyone else to hear. Simply plug your oscillators into the headphone monitor and tune them to the internal A440 tone in complete privacy. The A440 tone has a dedicated volume control so it can be removed from the headphone mix entirely. This is useful for when you want to tune oscillators to some other frequency, or just for having a private mix of any two signals in your synthesizer.

The TLN-867 also features a handy beat frequency indicator with four LEDs that provide a visual indication of the frequency difference between the left and right inputs, or either the left or right input with the A440 reference tone.

Description of panel controls:

- A440 pot: Sets the level of the A440 tone sent to the headphone monitor.
- PHONES pot: Sets the level of the signal at the PHONES jack.
- MODE switch: In the STEREO position, the signal at the LEFT jack goes to the left headphone speaker and the signal at the RIGHT jack goes to the right headphone speaker. In the MONO position, the signals at the LEFT and RIGHT inputs are summed and go to both headphone speakers. MONO mode is also handy for checking for phase cancellation between two signals.
- BEAT switch: Sets which two signals are applied to the beat frequency circuit. This is a three position switch. In the upper (LEFT) position, the signal at the LEFT jack and the A440 tone are used. In the lower (RIGHT) position, the signal at the RIGHT jack and the A440 tone are used. In the middle position (LEFT+RIGHT), the signals at the LEFT and RIGHT jacks are used.
- LEDs: The four LEDs are the output from the beat frequency circuit. They provide a visual indication of the frequency difference between the two inputs to the beat frequency circuit.
- LEFT jack: The input for the left channel.
- RIGHT jack: The input for the right channel.
- A440 jack: Output for the A440 tone (always 10Vpp).
- PHONES jack: Plug your headphones in here.

The beat frequency indicator works well at all audible frequencies. Below 50 Hz, flashing of the LEDs becomes noticeable. But if you can get used to that, you can even tune LFOs. You can also use it to tune oscillators to integer ratios (2:1 and 3:1). The LEDs do not rotate in this case, but they do flicker at the beat frequency (or multiples of the beat frequency).

2. Circuit Description

There are three distinct parts to this circuit: the A440 tone generator, the headphone amplifier, and the beat frequency indicator.

The A440 tone generator, as shown in the upper third of page 1 of the schematic, is nearly identical to Dave Brown's circuit (<http://modularsynthesis.com/a440/A440.htm>). U3, the DJB-440, is an Atmel ATTINY25 microcontroller which Dave has programmed to output a 440 Hz square wave on pin 5 and a 43.7 KHz square wave on pin 6. U4 (a Maxim MAX7401 8th order switched capacitor filter) changes the 440 Hz square wave into a 440 Hz sine wave. The 440 Hz sine wave is then amplified to 10Vpp levels by U5a. The only significant difference from Dave's circuit is the addition of C33 to pin 2 of U4. I noticed an odd "motor boating" sound in the sine wave output from U4. It was quiet, but still noticeable at high volume levels. I was able to eliminate this artifact by using a capacitor to "prefilter" the square wave output from U3 at the input of U4.

The headphone amplifier, as shown in the middle of page 1 of the schematic, consists of two op-amp summing amplifiers for the left and right channels. The inputs to the LEFT and RIGHT jacks are AC-coupled via C29 and C30 and combined with the 440 Hz sine wave via U1. Note that the 440 Hz sine wave is taken after VR2 (the A440 level pot) so that the A440 tone can be completely removed from the headphone signal. Switch SW1 uses passive mixing to sum the left and right signals to mono. The left and right signals then pass through VR1 (the PHONES level pot, a dual pot) to the headphone driver amp. U2 is an NE5532 audio op-amp which has sufficient power to drive headphones.

The beat frequency indicator is shown on page 2 of the schematic. The output half of this circuit comprises U11 through U13 and is fairly straightforward. Two square wave signals, A and B, are divided by two (by U11) to produce HA and HB (half frequency A, and half frequency B). Signals A, B, HA, HB and their inversions are combined by U12 and U13 to produce rectangular waves with a duty cycle that changes with the phase difference between the A and B signals. These signals drive LEDs 1-4 which, if arranged correctly, creates a rotating effect as the A and B signals are brought to nearly the same frequency. Note that the period of rotation is half the difference between the frequencies of the A and B signals. C34 and C35 are "deglitching" caps that were added to improve reliability in noisy environments.

Generating the A and B signals is a bit more complicated because there are three possible inputs to U11: the LEFT input, the RIGHT input, and the A440 tone. This is accomplished using a ternary (three state) to binary logic converter to select two inputs

from three. SW2 is a three state (on-none-on) switch that generates three possible logic states. These are converted by Q2 and Q3 to binary logic states as follows:

SW2 Switch Position	Voltage at SW2 Centre Pin	Ternary Logic State	SA State	SB State
upper (LEFT+A440)	0	0	0	0
middle (LEFT+RIGHT)	5	2	1	1
lower (RIGHT+A440)	2.5	1	0	1

The SA and SB control signals, along with the A440 square wave, and square wave versions of the LEFT and RIGHT signals are combined by U9 and U10 to create the two A and B signals for U11. Thus, depending on the position of SW2, the following signals are compared by the beat frequency indicator: LEFT input and A440 tone, LEFT input and RIGHT input, or RIGHT input and A440 tone.

The LEFT and RIGHT inputs must be converted to square waves before they can be processed by the beat frequency indicator. This is accomplished by comparators U7 and U8.

The beat frequency indicator needs the inversion of the A signal (NOT_A). Unfortunately, there were no spare gates available in U9-U13 and no space left on the MUUB boards to install an additional 14-pin chip just to get another inverter. Q3/R33/R34 is a single transistor inverter for the NOT_A signal. If you have extra space, or if you build this circuit as part of another circuit and have spare gates, use a normal inverter instead of Q3/R33/R34 for the NOT_A signal.

3. *Construction Tips*

Use log pots for VR1 and VR2. Pay attention to placement of VR1, the PHONES level pot (a dual pot), because it may be larger than the Bourns or Spectrol pots that you are used to using and will require more space around it.

Use coax cable for the jack and pot connections. When hooking up coax between the PCB and pots, run two pieces of coax to each pot. Each pot requires two signals (on pins 3 and 2) and a ground connection on pin 1. Use the shield on the wire that connects to pin 2 as the ground connection to pin 1. For the wire that connects to pin 3 of the pot, connect the coax shield to ground at one end only. Clip the coax shield from the other end and cover with a piece of heat shrink tubing to prevent any stray strands from coming into contact with anything. At this clipped end, connect the core (inside) conductor to the pot lug. Use the same technique when connecting coax wires between PCBs (if you are building this circuit using MUUBs).

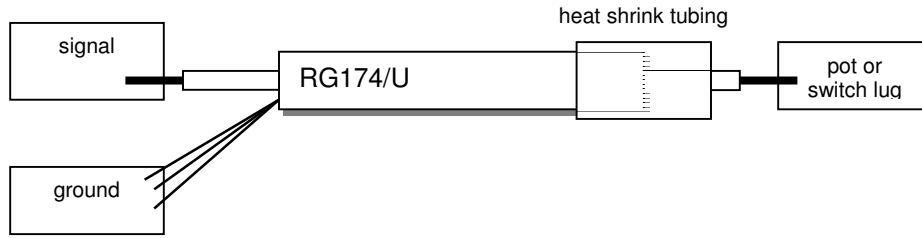

For VR1-VR2, the pin out for most pots is (left to right): 3, 2, 1 when viewing the back of the pot with the leads facing down. These pins are labeled on the schematic.

You can eliminate one wire to SW2 by soldering R28 directly to pins 1 and 3 of the switch.

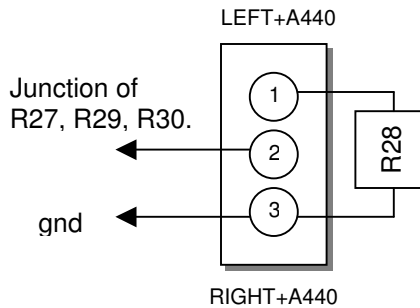

Switch SW2 viewed from behind (pins facing toward you). With switch in the up position (LEFT+A440) pins 2 and 3 are connected.

For the 78L05 regulator, the pin out is (left to right): 3, 2, 1 when viewing the front of the regulator (flat side facing you) with the leads facing down. These pins are labeled on the schematic.

You don't need to use 1% resistors for this circuit, 5% will work fine. I used 1% because I have lots on hand.

4. Modifications

The beat frequency indicator can be extended to 8 LEDs. This will require another flip-flop to divide the HA and HB signals down to quarter frequency, and a completely different summing network for U12 and U13. This is left as an exercise to the reader.

You can lower the gain of the headphone amplifier by either lowering R16 and R19, or by increasing R17 and R20. You can increase the signal to the headphones slightly by lowering R17 and R20.

5. ***Building the TLN-867 with MUUBs***

Be sure to check out the construction pictures on the website. Most of what I try to describe below can best be understood just by looking at the pictures.

You'll need one MUUB-4 and two MUUB-3s to build the TLN-867. If you look at the pictures on the website, you'll see the three boards mounted on the stooge brackets:

Board #1: MUUB-4 (bottom), board #1: headphone amp, +5V power, power connector

Board #2: MUUB-3 (top left), board #2: A440 (U3-U5), left comparator (U7), beat frequency indicator SA and SB signals (Q2, Q3, U9, U10)

Board #3: MUUB-3, board #3 (top right): right comparator (U8), inverter for the A signal (Q3), beat frequency indicator driver (U11-U13)

Prepare your panel and Stooge brackets before you do any soldering. Get all the mechanical issues dealt with first. You'll need one of the Stooge "flat plate modular brackets" and either two of the Stooge "2 jack modular brackets" or one of the "2 jack modular brackets" and one of the "one pot modular brackets". I didn't have any "one pot modular brackets" so I flattened out a "2 jack modular bracket" in a vice and bent it so that it was the same as a "one pot modular bracket".

Once you get the three bracket parts bolted together (use 1/4" #6 screws) and attached to the panel, you should have enough space to mount the MUUBs to the bracket using 1/4" spacers and 1/2" #6 screws. Make sure you leave enough space for the Switchcraft 112A jacks so that they don't interfere with the lower MUUB-4 board.

Before beginning the soldering, note the following labeling conventions used in this document for diodes, pots, and transistors.

1. Diodes: banded end is cathode, other end is anode.
2. Pots: when viewing the back of the pot (the shaft facing away from you) with the leads facing down, the pins are (left to right): 3, 2, 1.
3. Transistors: when viewing the front of the transistor (the flat side facing you) with the leads facing down, the pins are (left to right): 3 (collector), 2 (base), 1 (emitter).

Many parts go on the MUUB-3 boards in the "general purpose" area. This is no labeled grid in this section and thus it is near impossible to describe where to place the parts. Make use the website pictures to help determine where the parts go and all the jumpers that need to be installed. Here are some additional hints for the MUUB-3 boards.

1. Use both sides of the board to make connections.
2. There are two power busses located beneath each row of chips. Use the buss nearest the power supply connection for U9-U13 as a +5V buss, and use the buss nearest the ground connection for U9-U13 as a ground buss.
3. Leave the top two rows of the power busses free for hooking up the busses to +5V and ground.

4. Make all power supply connections (+5V and GND) to U9-U13 on the bottom-side of the board using small pieces of scrap resistor lead.
5. Any pins that need to be tied high or low for U11 should also be done on the bottom-side of the board using small pieces of scrap resistor lead.
6. Wires that need to cross from one side of a chip to the other should be made on the bottom-side of the board. If wires are made on the topside, make sure they won't interfere with inserting and removing chips from their sockets.
7. Use small pieces of scrap resistor lead to make short connections on either side of the board. Make sure the lead doesn't sit flat on the PCB touching the holes beneath it.
8. Attach power supply bypass caps (between the +5V buss and the GND buss) to the bottom-side of each chip near the power supply pin of each chip.
9. Place all other components on the topside of the board to make it easier to debug.
10. If you use sockets, make sure that they don't have exposed metal on the bottom of the socket that could come into contact with the power supply lines that run underneath the sockets.

5.1. Building Board #1 (MUUB-4)

This board contains the headphone amplifier and the +5V reference. This board has an additional bit of circuitry to construct in the lower left corner for the +5V reference. Study the schematic and the pictures on the website to see how I fit C19, C20, and U6 into that small square of 25 holes. Bend the leads of the components on the underside of the PCB to connect everything up. The centre pin of U6 connects to ground using the square hole of JD5. You will need one small wire to jumper U6 pin 1 to the +15V supply (the holes labeled V+ on the PCB). This is the small red wire in the website pictures. Place this wire in the hole to the left of U6 pin 1, then bend it underneath the PCB so that it touches U6 pin 1.

This circuit board also contains the power supply connector (MTA-156), two ferrite beads (L1-L2), and two 10 uF caps (C21 and C22). Power and ground will be supplied to the other two MUUBs by running wires from this board to the other boards.

Use the following table to place components from the TLN-867 schematic onto board #1. For short jumpers, use a scrap resistor lead. For longer jumpers, use a piece of #22 wire. Check the website pictures.

<i>Schematic</i>	<i>MUUB-4 Location (board #1)</i>
R7-100K	RC1
R8-100K	RC9
R9-200K	RC4
R10-1K	RC14
R11-100K	RD1
R12-100K	RD9
R13-200K	RD4
R14-1K	RD14
R15-100K	RA1
R16-100K	RA9

R17-100	RA14
R18-100K	RB1
R19-100K	RB9
R20-100	RB14
C1-100N	C5 (bypass cap for U1)
C2-100N	C6 (bypass cap for U1)
C3-100N	C3 (bypass cap for U2)
C4-100N	C4 (bypass cap for U2)
C21-10M	C1 (power supply bypass cap)
C22-10M	C2 (power supply bypass cap)
C27-33P	CA3
C28-33P	CB3
C29-3M3	RC8
C30-3M3	RD8
L1	L1 (ferrite bead)
L2	L2 (ferrite bead)
JP1	MTA-156 power connector
jumper	CC1, middle and bottom holes
jumper	RC5
jumper	RC6
jumper	JC4 (right hole) to JC5 (right hole)
jumper	RC13
jumper	TC2, middle to ground hole (at immediate left)
jumper	CD1, middle and top holes
jumper	RD5
jumper	RD6
jumper	JD4 (right hole) to JD5 (right hole)
jumper	RD13
jumper	TD2, middle to ground hole (at immediate left)
jumper	CA1, middle and bottom holes
jumper	RA13
jumper	TA2, middle to ground hole (at immediate left)
jumper	CB1, middle and top holes
jumper	RB13
jumper	TB2, middle to ground hole (at immediate left)

One additional wire is required on this board to jumper the SINE440 signal to both channels of the headphone amplifier (look for the orange wire in the website pictures for board #1). One side of this wire connects to the right hole of JD1. The other side connects to the right hole of JC2. Leave a long enough piece of wire exposed so you can bend it on the underside of the PCB to touch the right hole of JC1 when it's soldered in place. Don't solder anything into JC1 right now; a piece of coax wire will connect to JC1 later on.

5.2. Building Board #2 (MUUB-3)

This board contains the A440 tone generator (U3-U5), the left channel comparator (U7), and the SA and SB signal for the beat frequency indicator (Q2, Q3, U9, U10).

Comparator U7 is installed in the op-amp section of the MUUB-3 board. Everything else goes into the "general purpose" area. Use the following table to place components from

the TLN-867 schematic onto board #2 for the comparator. For short jumpers, use a scrap resistor lead. For longer jumpers, use a piece of #22 wire. Check the website pictures. Note that the comparator output is taken from the top hole of CB3 (you will need to run a jumper from the comparator output to U10 pin 12 on this board).

Schematic	MUUB-3 Location (board #2)
R21-10K	RA9
R22-1M	RA11
R23-10K	RB14
R39-100K	RA5
C7-100N	C3 (bypass cap for U7)
C8-100N	C4 (bypass cap for U7)
C31-100P	RA6
jumper	CA2, middle and bottom holes
jumper	CA4, middle and bottom holes
jumper	RA14
jumper	JA6
jumper	RB13 (left hole) to RB11 (left hole)
jumper	RB9 (right hole) to TA1 (middle hole)
jumper	JB9 (right hole) to +5V supply buss (running underneath U3-U5)

It is nearly impossible to describe how to connect all the components in the “general purpose” area of this board. Use the schematic, the hints provided previously in this document, the website pictures, and the following topside drawing as guides.

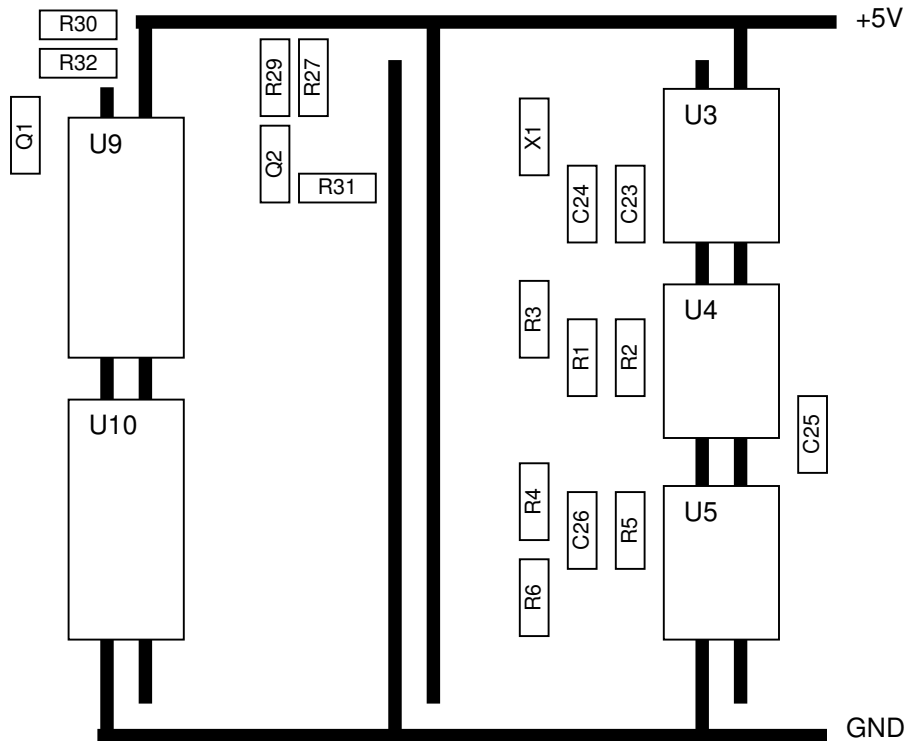

The following components are all installed on the underside of board #2: C5, C6, C11, C12, C16, C17, C18, C33. Each is a capacitor with one pin connected to ground.

U5 requires +/-15V power, not +5V and ground, on pins 8 and 4 respectively. There are two holes near the centre of the PCB (one connected to +15V, the other connected to -15V) that are near U5. Run wires from these holes to power U5. Connect the power supply bypass caps for U5 on the underside of the PCB from pins 8 and 4 to the ground buss that runs under U5.

5.3. Building Board #3 (MUUB-3)

This board contains the right channel comparator (U8), the inverter for the A signal (Q3), and beat frequency indicator driver (U11-U13).

Comparator U8 is installed in the op-amp section of the MUUB-3 board. Everything else goes into the “general purpose” area. Use the following table to place components from the TLN-867 schematic onto board #3 for the comparator. For short jumpers, use a scrap resistor lead. For longer jumpers, use a piece of #22 wire. Check the website pictures. Note that the comparator output is taken from the top hole of CB3 (you will need to run a jumper from the comparator output to U10 pin 1 on board #2).

<i>Schematic</i>	<i>MUUB-3 Location (board 32)</i>
R24-10K	RA9
R25-1M	RA11
R26-10K	RB14
R40-100K	RA5
C9-100N	C3 (bypass cap for U7)
C10-100N	C4 (bypass cap for U7)
C32-100P	RA6
jumper	CA2, middle and bottom holes
jumper	CA4, middle and bottom holes
jumper	RA14
jumper	JA6
jumper	RB13 (left hole) to RB11 (left hole)
jumper	RB9 (right hole) to TA1 (middle hole)
jumper	JB9 (right hole) to +5V supply buss (running underneath U11)

It is nearly impossible to describe how to connect all the components in the “general purpose” area of this board. Use the schematic, the hints provided previously in this document, the website pictures, and the following topside drawing as guides.

The following components are all installed on the underside of board #3: C13, C14, C15. Each is a capacitor with one pin connected to ground.

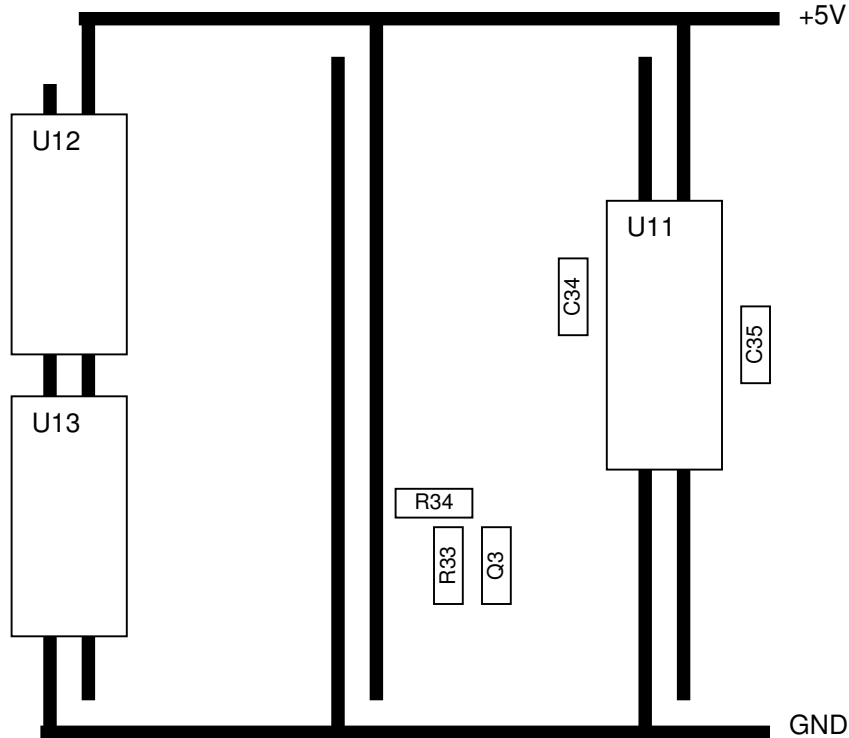

5.4. Power Considerations

You will need to run four wires from the MUUB-4 board to the two MUUB-3 boards (+/- 15V, +5V, and ground). The easiest place to jumper the +/-15V connections are the row of three holes marked V+ and V- on each of the MUUB boards. For the ground connection use the holes marked GND near the left edge of the board. For the +5V connection, run a wire from the 78L05 regulator output to the +5V buss on the “general purpose” area of the MUUB-3 boards. Jumper all the +5V busses together on each MUUB-3 board. Also jumper all the ground busses together on each MUUB-3 board. The easiest way to hook up the ground busses to GND is to jumper a wire from the ground buss nearest TB2 to the square hole immediately above it.

5.5. Board to Board Wiring

There are several wires that need to be hooked up between the MUUB boards. Use the table below to hook up these wires. The wire length and colour (as seen in the website pictures) are also given. Coax wire is not required, but is recommended in some places.

<i>Board # and Location</i>	<i>Board # and Location</i>	<i>Length (inches)</i>
board #1, JD6 (signal and ground)	board #2, JA5 (right hole, signal only)	6.5 (coax)
board #1, JC6 (signal and ground)	board #3, JA5 (right hole, signal only)	6 (coax)
board #3, CB3 (top hole)	board #2, U10 pin 1	2.5 (green)
board #2, U10 pin 8	board #3, R33 (input to inverter for A signal)	2 (blue)
board #2, U10 pin 6	board #3, U11 pin 12	1 (black)

5.6. Panel Wiring

Use coaxial cable to hook up the jacks and pots. You don't need coax cable for the LEDs or the switches. The coax connection for jacks is connected to ground at both the jack and on the PCB. Section 3 contains additional information about hooking up coax connections to the pots. The square holes on the PCB for the input and output connections (JA1-9, JB1-9, JC1-9, JD1-9) are ground.

The PHONES pot is a dual pot with an A and a B channel. The pins for this pot are labeled 3A, 2A, 1A for the left channel and 3B, 2B, 1B for the right channel (left to right, looking at the back of the pot with the pins facing down).

The MODE switch (SW1) can be hooked up directly to the PHONES pot (VR1) on the panel using two short pieces of wire (no need to use coax). Connect the middle and top lugs of SW1 to pins 3A and 3B of VR1. See the website pictures for an example.

<i>Panel Item</i>	<i>PCB connection</i>	<i>Length (inches)</i>
J1 (left input jack)	board #1 JD8, jack ground goes in left hole, jack signal goes in right hole	5.5 (coax)
J2 (right input jack)	board #1 JC8, jack ground goes in left hole, jack signal goes in right hole	5 (coax)
J3 (A440 output jack)	board #2 connect R6 to general purpose connection points near middle +5V buss, jack ground goes in left hole, jack signal goes in right hole	7 (coax)
J4 tip (phones left output)	board #1, JB9, jack ground goes in left hole, jack signal goes in right hole	3 (coax)
J4 ring (phones right output)	board #1, JA9, jack ground goes in left hole, jack signal goes in right hole	3 (coax)
SW1 MODE switch	connect middle and top lugs to pins 3A and 3B of VR1 (the PHONES pot)	2
SW2, top lug BEAT switch	connect to bottom lug of SW2 via R28	n/a
SW2, middle lug BEAT switch	board #2, junction of R27, R29, and R30	5
SW2, bottom lug BEAT switch	board #2, connect to ground buss	5
VR1, pin 3A PHONES pot	board #1, JD9, shield connected to ground at PCB end only	6.5 (coax)

VR1, pin 2A PHONES pot	board #1, JB1, shield connected to ground at PCB end and to VR1 pin 1A	6 (coax)
VR1, pin 1A PHONES pot	connect to ground using shield of coax wire connected to VR1 pin 2A	n/a
VR1, pin 3B PHONES pot	board #1, JC9, shield connected to ground at PCB end only	6 (coax)
VR1, pin 2B PHONES pot	board #1, JA1, shield connected to ground at PCB end and to VR1 pin 1B	5.5 (coax)
VR1, pin 1B PHONES pot	connect to ground using shield of coax wire connected to VR1 pin 2B	n/a
VR2, pin 3 A440 pot	board #2, connect to junction of C25 and R4, use general purpose connection points near U5, shield connected to ground at PCB end only	6.5 (coax)
VR2, pin 2 A440 pot	board #1, JC1, shield connected to ground at PCB end and to VR2 pin 1	8 (coax)
VR2, pin 1 A440 pot	connect to ground using shield of coax wire connected to VR2 pin 2	n/a
LED1	board #3, anode (longer lead) connects to +5V, cathode connects to U13 pin 3 via R35	3
LED2	board #3, anode (longer lead) connects to +5V, cathode connects to U13 pin 6 via R36	3
LED3	board #3, anode (longer lead) connects to +5V, cathode connects to U13 pin 8 via R37	3
LED4	board #3, anode (longer lead) connects to +5V, cathode connects to U13 pin 11 via R38	3

The easiest way to hook up resistors R35-R38 is to solder them directly to the cathodes of the LEDs (rather than mounting them on the PCB). Then run wires from the anode to +5V and from the other end of the resistor to U13. Be sure to cover the exposed wires and resistor with heat shrink tubing.

6. Testing

This circuit requires no calibration and is very simple to test. Before you apply power for the first time, it's a good idea to remove all chips from the sockets and check for any wiring errors. Apply power and check that the correct voltage levels are present at the sockets (where the chips will eventually go). If the power connections all appear correct, turn off power, insert the chips, and power on again.

The A440 tone generator requires very little to operate (just power and a crystal). Use a scope to check for the existence of a 440 Hz square wave on pin 5 of U3. If that looks good, then you should see a 440 Hz sine wave on pin 5 of U4. If that looks good then you should also see a 440 Hz sine wave at approximately 10Vpp on pin 1 of U5.

Turn the A440 volume pot fully clockwise (on). You should see the 440 Hz sine wave on pins 1 and 7 of U1. Turn the PHONES pot fully clockwise (on) but don't plug in any headphones. You should see the A440 sine wave on pins 1 and 7 of U2.

To test the left channel, turn the A440 volume pot fully counter-clockwise (off). Plug a 10 Vpp sine wave, or triangle wave, from an oscillator into the LEFT input. You should see the oscillator on pin 7 of U1. Turn the PHONES pot fully clockwise (on) and you should see the same signal on pin 7 of U2. Attach the scope to pin 1 of U2. Change SW1 between MONO and STEREO. You should see the oscillator signal on pin 1 when SW1 is set to MONO only.

To test the right channel, repeat the above procedure with an oscillator plugged into the RIGHT input and look for the oscillator signal on pin 1 of U1 and U2 (it should be there all the time when the PHONES pot is fully clockwise). Also check that the signal appears on pin 7 of U2 only in MONO mode.

Turn the PHONES level fully counter-clockwise (off). Plug a couple of 10 Vpp oscillators into the left and right channels (sine or triangle waves). Plug some headphones into the PHONES jack and slowly turn up the volume until you can hear them. Make sure the oscillators are set to an audible range. Slowly turn up the A440 level pot to a comfortable listening level. Tune the oscillators so that they are nearly in tune with the A440 signal.

Attach your scope probe to pin 7 of U7. You should see a square wave version of the signal at the LEFT input. Attach your scope probe to pin 7 of U8. You should see a square wave version of the signal at the RIGHT input.

Attach your scope to pin 4 of U11. As you change the BEAT switch you should see either the A440 square wave or the LEFT input square wave. Check pins 6 and 7 of U11. You should see square waves of half the frequency seen at pin 4.

Attach your scope to pin 12 of U11. As you change the BEAT switch you should see either the RIGHT input square wave or the LEFT input square wave. Check pin 10 of U11. You should see a square wave of half the frequency seen at pin 12.

Turn the A440 pot fully counter-clockwise (off). Turn the BEAT switch to the middle position (LEFT+RIGHT). Tune the oscillators to match each other and watch the LEDs. Try tuning the oscillators to different frequencies (100 Hz, 1000 Hz, 10000 Hz). Also try tuning the oscillators to integer multiples of each other. In all cases you should see a rotating or pulsating pattern on the LEDs that appears to stop moving once the oscillators are in tune.

Disconnect the RIGHT input and turn the A440 pot clockwise until you can hear it at a comfortable level along with the LEFT input signal. Turn the BEAT switch to the upper position (LEFT+A440). Tune the oscillator to A440 and watch the LEDs. Try tuning the oscillator to integer multiples of 440 Hz by observing the LEDs.

Disconnect the oscillator from the LEFT input and reconnect the oscillator at the RIGHT input. Turn the BEAT switch to the lower position (RIGHT+A440). Try tuning the oscillator to integer multiples of 440 Hz by observing the LEDs.

TLN-867 Parts List

Resistors (40)

Quantity	Description	Part No.	Notes
2	100	R17, R20	5% or better, Mouser #291-100
4	330	R35, R36, R37, R38	5% or better, Mouser #291-330
3	1K	R6, R10, R14	5% or better, Mouser #291-1K
1	1.2 K	R3	5% or better, Mouser #291-1.2K
9	10 K	R21, R23, R24, R26, R27, R28, R31, R32, R34	5% or better, Mouser #291-10K
1	44.2 K	R4	1% or better, Mouser #271-44.2K
1	47 K	R33	5% or better, Mouser #291-47K
13	100 K	R1, R2, R5, R7, R8, R11, R12, R15, R16, R18, R19, R39, R40	5% or better, Mouser #291-100K
2	200 K	R9, R13	5% or better, Mouser #291-200K
2	330 K	R29, R30	5% or better, Mouser #291-330K
2	1 M	R22, R25	5% or better, Mouser #291-1M

Capacitors (35)

Quantity	Description	Part No.	Notes
2	18 pF ceramic	C23, C24	Mouser #140-50N5-180J
3	33 pF ceramic	C26 – C28	Mouser #140-50N5-330J
2	100 pF ceramic	C31, C32	Mouser #140-50N5-101J
2	1N ceramic	C34, C35	Mouser #147-75-102
21	100N ceramic	C1 – C19, C25, C33	Mouser #147-72-104 Mouser #581-SA105E104M
2	3.3 uF non-polar elec.	C29, C30	Mouser #140-NPRL50V3.3
3	10 uF 35V elec.	C20 – C22	Mouser #140-XRL35V10

Semiconductors (20)

Quantity	Description	Part No.	Notes
2	TL072 dual op amp	U1, U5	Allied #735-2727 Mouser #595-TL072CP Digikey #296-1775-5-ND
1	NE5532 dual op amp	U2	Mouser #595-NE5532AP
1	DJB-440 A440 tone generator	U3	Contact Dave Brown: www.modularsynthesis.com
1	MAX7401	U4	www.maxim-ic.com
1	LM78L05	U6	Mouser #511-L78L05ACZ
2	LM311N comparator	U7, U8	Mouser #511-LM311N Digikey #LM311NNS-ND
1	74HC132	U9	Mouser #511-M74HC132
2	74HC00	U10, U13	Mouser #511-M74HC00
1	74HC109	U11	Mouser #511-M74HC109
1	74HC02	U12	Mouser #511-M74HC02
2	BC549B transistor (NPN)	Q1, Q3	Mouser #625-BC549B, (can substitute BC550)
1	BC559B transistor (PNP)	Q2	Mouser #625-BC559B, (can substitute BC560)
4	Lumex green LEDs	LED1 – LED4	Digikey #67-1156-ND

Potentiometers & Trimmers (2)

Quantity	Description	Part No.	Notes
1	100 K dual log pot	VR1 (Phones)	Mouser #313-2420F-100K
1	100 K log pot	VR2 (A440)	Bourns 91 series, Allied #754-9820 Mouser #652-91A1A-B24-D20

Miscellaneous

Quantity	Description	Part No.	Notes
3	mono phone jack Switchcraft 112A	J1 – J3	Allied #932-9391 Mouser #502-112A
1	stereo phone jack Switchcraft 112B	J4	Mouser #502-112B
2	axial ferrite bead	L1, L2	Active #MURJP2141 Mouser #623-2743002112
1	5.0688 MHz crystal	X1	Mouser # 520-HCA506-20X
1	SPDT switch (two position -on, none, on) NKK M2012ES1W01	SW1	Allied #870-8646 Mouser #633-M201202
1	SPDT switch (three position -on, off, on) NKK M2013ES1W01	SW2	Mouser #633-M201302
1	16 pin DIP socket		
4	14 pin DIP socket		
7	8 pin DIP socket		
1	MTA-156 4 pin header	JP1	Mouser #571-6404454 Digikey #A1973-ND

Hardware

Quantity	Description	Notes
2	knob ALCO PKES90B1/4	Mouser # 506-PKES90B1/4
1	TLN-867 panel	front panel
1	MUUB-4	printed circuit board
2	MUUB-3	printed circuit board
2	2 jack modular bracket (see construction notes)	Stooge bracket
1	flat plate modular bracket	Stooge bracket
	#6-32 screws (1/4", 1/2", 3/4", 1") spacers (1/4", 3/8") #6-32 nuts #6-32 lock washers	Mouser part numbers: 534-405, 534-407 (spacers) 5721-632-1/4, 5721-632-1/2, 5721-632-3/4 (screws) 5721-632 (nuts), 5721-LWI-6 (lock washers) (for mounting main circuit boards to Stooge bracket)
	pot nut	Mouser #534-1456 (for mounting Stooge bracket to front panel)
1	MTA-156 power cable	Mouser #571-6404264 (connector) Mouser #571-6405514 (dust cover)
4	#8-32 black screw	(for mounting module to cabinet)
	cable ties	
	hookup wire	
	solder	both organic and no clean



A440



PHONES

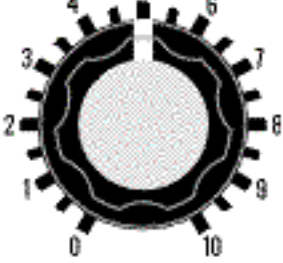

MODE

STEREO



MONO

BEAT

LEFT



RIGHT



LEFT



RIGHT



A440



PHONES



TELLUN CORP
TUNER MONITOR

